



## COMPARATIVE ANALYSIS OF TECHNOLOGICAL PROCESSES OF KURITSKY EQUIPMENT 2SV-10 AND TOWER DRYING EQUIPMENT

Madaminjon Ubaydullayev

PhD, Head of the Department of Natural Fibers,  
Fergana Polytechnic Institute, Fergana, Uzbekistan

E-mail: [mubaydullayev6554@gmail.com](mailto:mubaydullayev6554@gmail.com)

Yuldashali Ergashov

Candidate of Technical Sciences, Docent, Department of Natural Fibres,  
Fergana Polytechnic Institute, Fergana, Uzbekistan

E-mail: [yuldashaliergashov@gmail.com](mailto:yuldashaliergashov@gmail.com)

Ilyosjon Mahmutaliyev

Master's student, Department of Natural Fibres,  
Fergana Polytechnic Institute, Fergana, Uzbekistan

E-mail: [ilyosbekmahmutaliyev4@mail.com](mailto:ilyosbekmahmutaliyev4@mail.com)

### Abstract

In this article, technical and technological indicators, advantages and disadvantages of SBO and 2 SBO10 drying equipment in the technological process of cotton drying at the Rishton cotton ginning plant were considered. Also, information about the tests of Namangan 77 and Andijan selection varieties of cotton raw material for the analysis was disclosed.

**Keywords:** cotton, drum, drying, dirtiness, amount of heat, selection, humidity.

### Introduction

It is known that our country is one of the countries with a developed cotton industry. It ranks 4th in cotton production and 2nd in export. The quality of our produced products depends on drying them at a standard level. We conducted experiments in 2 separate cotton-ginning enterprises [1-7].

Comparative analysis of technological processes of drying equipment 2CB-10 and tower dryer equipment in cotton ginning enterprises operated by Rishton Cotton Refinery LLC and Bohodir Log'on Tekistil LLC joint facility and study of the effect of seed cotton characteristics on technological processes and technological processes Rishton cotton ginning and Bahadir logan textile LLC joint ventures

were selected for the experiment. 2CB-10 drying equipment was installed in the Rishton cotton ginning enterprise and Namangan 77 was used for analysis. 1st class 1 seed cotton with 10% moisture content and 5% impurity of selection cotton variety was selected and experimental tests were carried out.

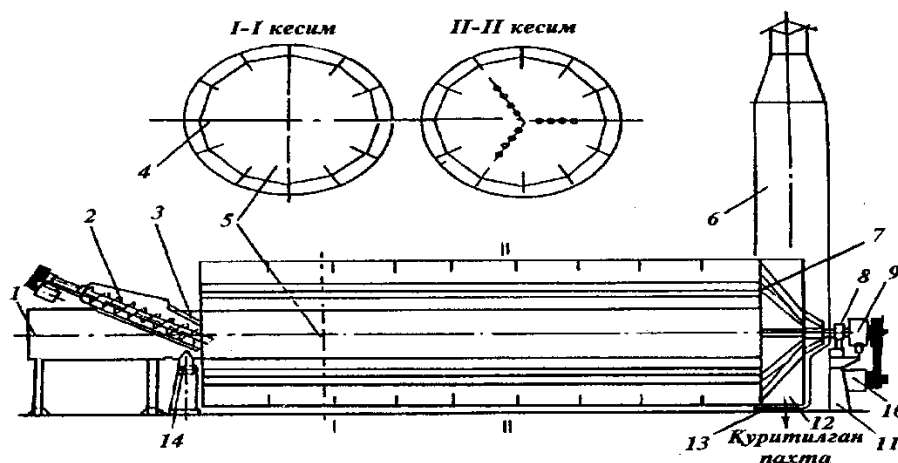

Figure 1. 2SB-10 dryer drum diagram

1-drying agent pipeline; 2-screw feeder; 3rd front row; 4 - shovels; 5th drum; 6th chimney; 7- skewers; 8 - bearing; 9 - reducer; 10 - electric motor driving the drum; 11 and 14 - back and front supports; 12-drop shovel; 13 - landing gear.

Seeded cotton with a moisture content of 10% and impurities of 5% was fed to the drum and heated at 100 °C.

In order to prevent cotton from getting stuck in the dryer with tower drying equipment installed at the joint enterprise "Bohodir Log'on Tekistil LLC", the airflow in the air conveyor is 20-25m/s, and the front part of the shelves is placed at 45° relative to the horizontal, and the raw cotton material is 10-12m falls onto the tower dryer shelf at a speed of /s. In the dryer, it moves at a speed of 7-8 m/s. The time of dividing cotton raw material in the drying equipment is 10-15 seconds. Therefore, the moisture separation of the tower dryer is 2-3%. The productivity of dry cotton is 2000 kg in the first stage when the drying agent temperature is 110 °C for dehumidification of 8000 kg/h [14-21].

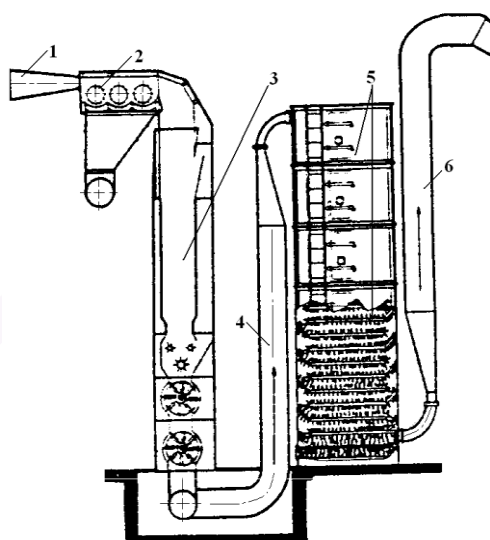

Figure 2. Diagram of a tower dryer

Here: 1 - pipe, 2 - equipment for cleaning small impurities, 3 - hopper feeder, 4 - pipe for transporting cotton raw material and drying agent, 5 - shelves of drying equipment, 6 - pipe for transporting cotton raw material and drying agent.

In order to prevent the cotton from getting stuck in the dryer, the front part of the shelves is placed at 45° to the horizontal, the airflow is 20-25 m/s, and the raw cotton material falls on the tower dryer shelf at a speed of 10-12 m/s. In the dryer, it moves at a speed of 7-8 m/s. The time of dividing cotton raw material in the drying equipment is 10-15 seconds. Therefore, the moisture separation of the tower dryer is 2-3%. The productivity of dry cotton is 8000 kg/hour, the temperature of the drying agent for moisture separation is 2000 kg in the first stage when it is 110 °C, it is 100 °C when it is given seeded cotton of Namangan 77 selection cotton grade 1 with a moisture content of 10% and dirtiness of 5%. The moisture content of the seeded cotton was 8% and the dirt content was 3.5%. It can be seen that the drying efficiency of the tower dryer was 2% and the cleaning efficiency was 1.5%.

## Conclusion

In conclusion, when analyzing the drying equipment, the moisture separation indicators of the drum drying equipment were 3% in 2CBO-10. It was 2% in the tower dryer. This shows that the selected selection variety has achieved a high result in the drum dryer. It has been confirmed that the selection of seeds of cottonseed has an effect on the equipment of technological processes of drying.



## References

1. N.A.Navruzov., I.D.Madumarov., N.M.Axmatov., M.A.Axmatov., Yuqori navli paxta xom ashyo SI №2/2009. 104-106 б.
2. Ubaydullayev, M. M. (2022). Yangi defoliantlar hosildorlik garovi. Архив научных исследований, 2(1).
3. Mo'minjonovich, U. M. (2022). Effectiveness Of Defoliants. Eurasian Research Bulletin, 8, 9-12.
4. Mominjonovich, U. M., & Ogli, M. I. V. (2022). Study and analysis of technological processes of cotton drying in a cluster system. International Journal of Advance Scientific Research, 2(11), 6-10.
5. Ubaydullaev, M. M., & UT, T. (2022). Determination of appropriate norms and terms of defoliants. American Journal Of Applied Science And Technology, 2(05), 18-22.
6. Ubaydullaev, M. M., & Makhmudova, G. O. (2022). Medium fiber s-8290 and s-6775 cotton agrotechnics of sowing varieties. European International Journal of Multidisciplinary Research and Management Studies, 2(05), 49-54.
7. 6.Ubaydullaev, M. M., & Komilov, J. N. (2022). Effect of defoliants for medium fiber cotton. International Journal of Advance Scientific Research, 2(05), 1-5.
8. Ubaydullaev, M. M., & Mahmutaliyev, I. V. (2022). Effectiveness of foreign and local defoliants on the opening of cups. International Journal of Advance Scientific Research, 2(05), 6-12.
9. Ubaydullaev, M. M., & Sulstonov, S. T. (2022). Defoliation is an important measure. European International Journal of Multidisciplinary Research and Management Studies, 2(05), 44-48.
10. Ubaydullaev, M. M., & Nishonov, I. A. (2022). The Benefits of Defoliation. Eurasian Journal of Engineering and Technology, 6, 102-105.
11. Ubaydullayev Madaminjon Mo'minjon o'g'li, & Ma'rufjonov Abdurahmon Mo'sinjon o'g'li. (2022). Biological efficiency of foreign and local defoliants. "science and innovation" international scientific journal, 1(2). <https://doi.org/10.5281/zenodo.6569808>
12. 1(2). <https://doi.org/10.5281/zenodo.6569808>
13. Ubaydullayev, M. M. (2021). G 'o 'zada defoliatsiya o 'tkazishning maqbul me'yor va muddatlari. Monografiya.-Corresponding standards and terms of defliation of cotton. Monograph.-. Соответствующие нормы и сроки дефолиации хлопка. Монография. Zenodo.



14. Ubaydullaev, M. M. (2020). The importance of sowing and handling of c-8290 and c-6775 seeds in the conditions of the meadow soils of the Fergana area. In International conference on multidisciplinary research (p. 11).
15. Ubaydullayev, M. M., & Ne'matova, F. J. (2021). The importance of planting and processing of medium-fiedl cotton varieties between cotton rows in Fergana region. The American jurnal of agriculture and biomedical engineering. USA, 3(09).
16. Тешаев, Ф. Ж., & Убайдуллаев, М. М. (2020). Определение эффективных норм новых дефолиантов в условиях лугово-солончаковых почв Ферганской области при раскрытии коробочек 50-60% сортов хлопчатника с8290 и с6775. Актуальные проблемы современной науки, (5), 62-64.
17. Mo'minovich, U. M. (2021). The Importance Of Planting And Processing Of Medium-Field Cotton Varieties Between Cotton Rows In Fergana Region. The American Journal of Agriculture and Biomedical Engineering, 3(09), 26-29.
18. Ubaydullayev, M. M., Ne'matova, F. J., & Marufjonov, A. (2021). Determination of efficiency of defoliation in medium-fiber cotton varieties. Galaxy International Interdisciplinary Research Journal, 9(11), 95-98.
19. Ubaydullaev, M. M. U., Askarov, K. K., & Mirzaikromov, M. A. U. (2021). Effectiveness of new defoliant. Theoretical & applied science Учредители: Теоретическая и прикладная наука,(12), 789-792.
20. Usmonov, J. M., Shakirov, S. M., Ubaydullayev, M. M., & Parmonov, S. O. (2021). Aluminum-based composition materials for processing aluminum scrap. ACADEMICIA: An International Multidisciplinary Research Journal, 11(8), 19.Убайдуллаев, М. М., Шакиров, Ш. М., Усмонов, Ж. С., & Пармонов, С. Т. (2021). Электр двигателларда қўлланиладиган углеграфитли материалларни ишлаб чиқариш технологиясини таҳлил қилиш. Композицион материаллар”, Тошкент ш, 103-107.
21. Кодиров, З. З., Ирискулов, Ф. С., Пулатов, А., & Убайдуллаев, М. (2018). Electronic libraries as a fact of contemporary information landscape. Экономика и социум, (3), 629-633.